

Pro Configuration

Requirements

Amp Head with a speaker output
A/B (and/or) switchbox
Speaker/Amp combo or Amp Head with speakers
Microphone with a P.A. system (amp & speaker)

1. Hook your guitar up to any pre-amp effects you desire (Crybaby, Distortion, etc.).
2. Have the last item in your pre-amp effects go into an A/B switchbox or similar switching device that accepts one input and has two outputs.
3. Connect your Amp Head to one output of the A/B box and connect your Speaker/Amp combo or Amp Head with speakers to the other output of the A/B box.
4. Connect a cable from the speaker output of your Amp Head to the input of the **Talkbox**. (Be sure to use a heavy duty speaker cable, not a standard guitar cable.) Caution: The **Talkbox** is an 8 ohm speaker rated at 100 watts max power or 50 watts RMS. Check the specifications on your amplifier to verify that it will not overpower the **Talkbox**.
5. Put the end of the **Talkbox**'s clear tube up alongside your microphone, so that the tube fits in your mouth. Make sure the tube is close to the microphone to achieve best results from the effect. (Have your microphone set up as you normally would using another amp and speaker.)
6. The A/B box will allow you to control whether you hear (A) the regular, unmodified sound of your guitar, (B) the **Talkbox** effect going to your microphone, or (A & B) both at the same time.
7. You are now ready to recreate the vintage sounds of the **Talkbox**! Practice moving your mouth and tongue to produce vowels and consonants while playing single notes on your guitar.

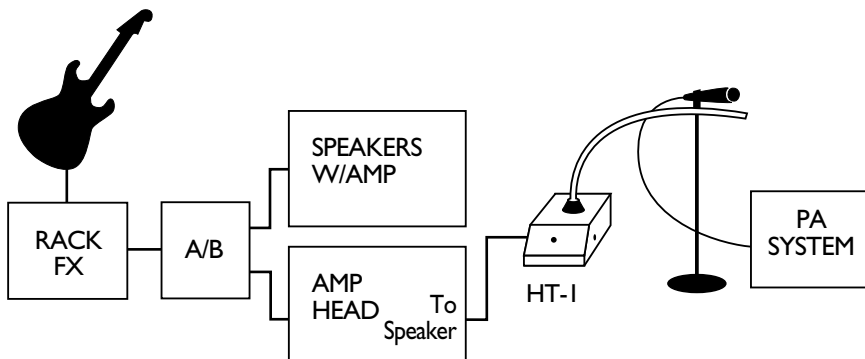

The **Talkbox** is one of the most innovative and unique effects device ever created. From its introduction to this day, it's been used on hit record after hit record. Its sturdy construction and ease of use will give you years of reliable performance.

Operating Instructions

The **Talkbox** takes the signal from your Amplifier SPEAKER OUTPUT and sends it through the hose. Place the hose in the corner of your mouth, between your back teeth. To make the instrument "talk", mouth the words into the microphone while simultaneously playing your instrument. Do not make any sound with your voice. Begin by mouthing the vowels A, E, I, O, U. You'll find that the more exaggerated you form your mouth, the better the effect will sound. Next, work on saying words with the hard consonants, such as B, D, G, J, K, P, Q, T. Then move on to phrases and complete sentences. When you bite down partially on the hose, the sound will change; however, if you bite down completely, it cuts off the sound.

Tips

Listen to some of the music the **Talkbox** has been used on, for example, Peter Frampton's "Do You Feel Like We Do". This is one of the best examples of what can be done with the **Talkbox**. Frampton uses complete phrases and combines them with his soloing, harmonizing with his voice. Some other examples of **Talkbox** use are Joe Walsh's "Rocky Mountain Way", Alice in Chains' "Man in a Box", Scorpions' "The Zoo" and Slash's "Dust and Bones."



CAUTION

Do Not use the **Talkbox** with a high wattage amplifier. Also, be sure that both your instrument amplifier and microphone amplifier are GROUNDING.

Jim Dunlop
USA

Basic Configuration

Requirements

Amp Head with a speaker output
Microphone with a P.A. system (amp & speaker)
8 ohm speaker or speaker cabinet

1. Hook your guitar up to any pre-amp effects you desire (Crybaby, Distortion, etc.).
2. Have the last item in your pre-amp effects go into the input of your Amp Head.
3. Connect a cable from the speaker output of your Amp Head to the input of the **Talkbox**. (Be sure to use a heavy duty speaker cable, not a standard guitar cable.) Caution: The **Talkbox** is an 8 ohm speaker rated at 100 watts max power or 50 watts RMS. Check the specifications on your amplifier to verify that it will not overpower the **Talkbox**.
4. Connect your 8 ohm speaker or speaker cabinet to the output of the **Talkbox**. When the **Talkbox** is on, the signal is passed up through the tube. When switched off, the sound is passed unaltered through to the speaker.
5. Put the end of the **Talkbox**'s clear tube up alongside your microphone, so that the tube fits in your mouth. Make sure the tube is close to the microphone to achieve best results from the effect. (Have your microphone set up as you normally would using another amp and speaker.)
6. You are now ready to recreate the vintage sounds of the **Talkbox**! Practice moving your mouth and tongue to produce vowels and consonants while playing single notes on your guitar.

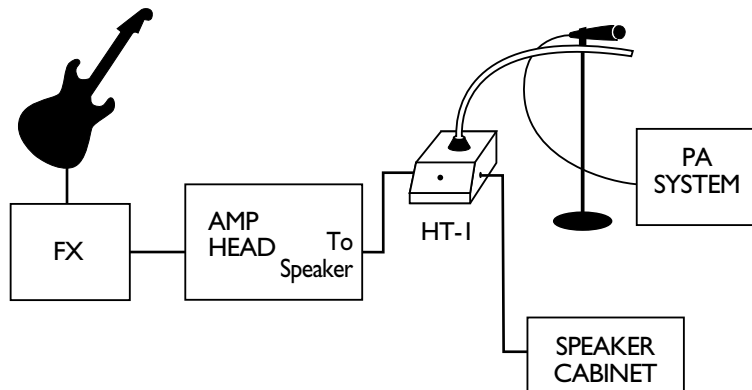

Keyboard Configuration

Requirements

Amp Head with a speaker output
Speaker/Amp combo or Amp Head with speakers
Microphone with a P.A. system (amp & speaker)

1. Connect a line-level output of your keyboard to the input of the Amp Head.
2. Connect a cable from the speaker output of your Amp Head to the input of the **Talkbox**. (Be sure to use a heavy duty speaker cable, not a standard guitar cable.) Caution: The **Talkbox** is an 8 ohm speaker rated at 100 watts max power or 50 watts RMS. Check the specifications on your amplifier to verify that it will not overpower the **Talkbox**.
3. Connect another line-level output of your keyboard to the input of your Speaker/Amp combo or Amp Head with speakers.
4. Put the end of the **Talkbox**'s clear tube up alongside your microphone, so that the tube fits in your mouth. Make sure the tube is close to the microphone to achieve best results from the effect. (Have your microphone set up as you normally would using another amp and speaker.)
5. You are now ready to recreate the vintage sounds of the **Talkbox**! Practice moving your mouth and tongue to produce vowels and consonants while playing single notes on your keyboard.

